

309BM.60 | 309BM - Magnetic levels





Standards:

DIN 877

Description:

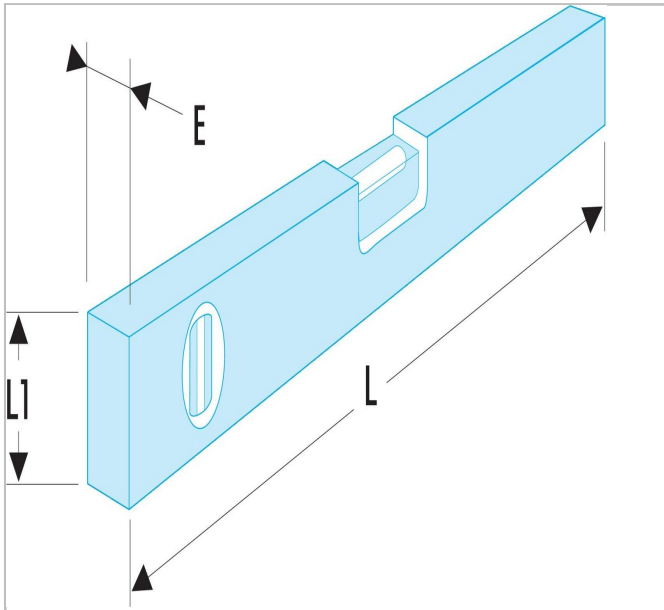
- In reverse position, accuracy 1 mm/m.
- Light alloy body, drawn.
- Smooth anodized surfaces (easy cleaning).
- Vertical vial and horizontal vial.



 309BM.60	
Length L [mm]	600.0
Length L1 [mm]	50.0
Thickness E [mm]	21.0
Weight [g]	80.0