

805.1 | 805 - Universal calipers class 0 - 1/50th

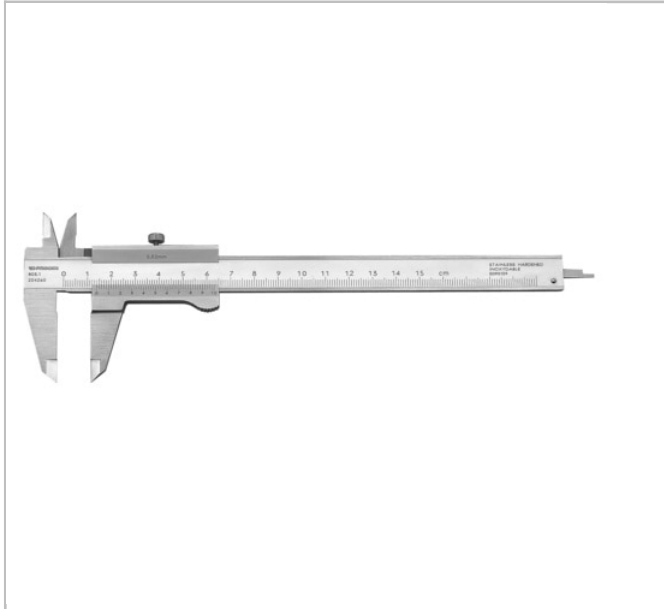



Standards:

NF EN ISO 13385-1, ISO 13385-1, DIN 862

Description:

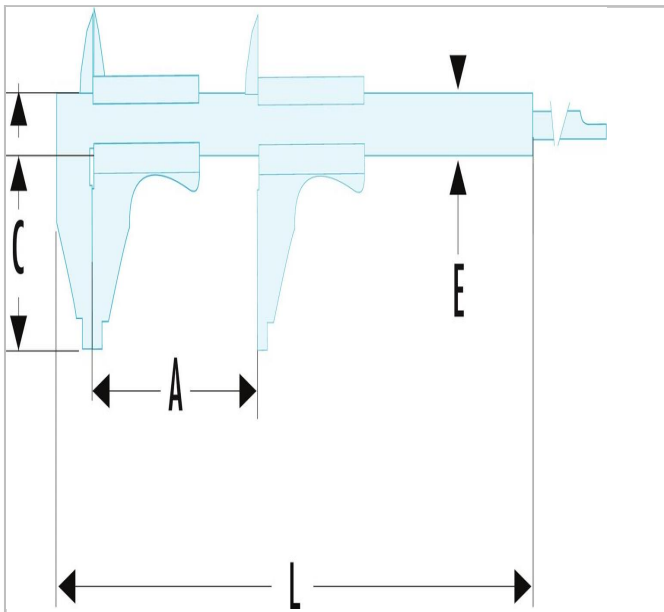
- Accuracy: 1/50th - 0.02 mm.
- Interior, exterior, depth measurement.
- Stainless steel rule - mat finish.
- Rule hardness: 40 HRc minimum.
- Flat depth gauge.
- Vernier with guide for better thumb position.
- Vernier endurance: 20 000 cycles minimum.
- Vernier screw locking.
- Supplied in case with compliance certificate.



	805.1
A [mm]	150.0
Thickness E [mm]	16.0
Head Height C [mm]	40.0
Accuracy [mm]	0.02
Bias Error ["]	20.0
Weight [g]	290.0