

805.M | Caliper class 0 - 1/50th

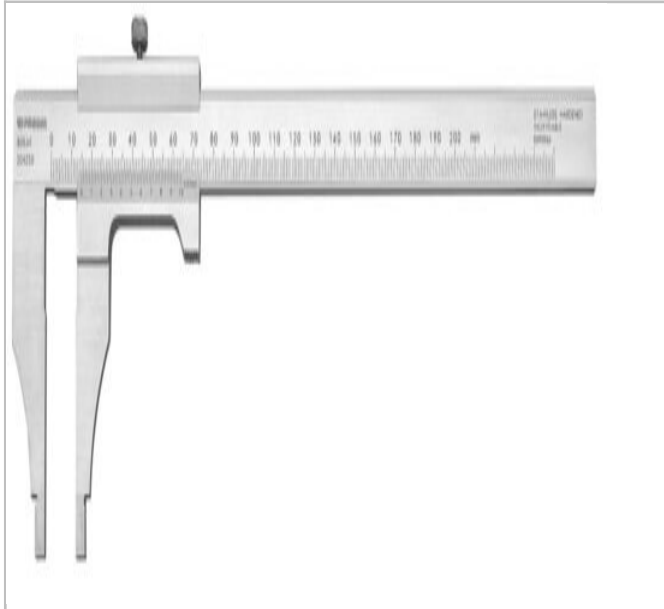



Standards:

**NF EN ISO 13385-1, ISO 13385-1,
DIN 862**

Description:

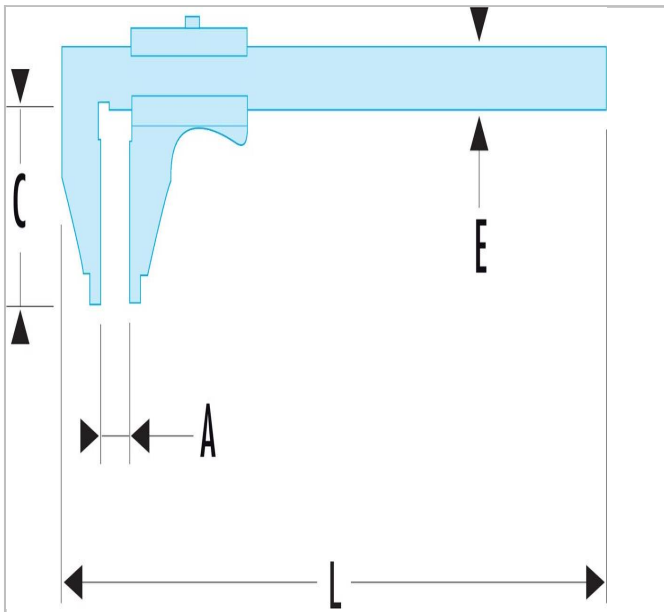
- Accuracy: 1/50th - 0.02 mm.
- Measurement capacity: 200 mm.
- Interior, exterior measurement (bore exceeding 10 mm).
- Stainless steel rule - mat finish.
- Rule hardness: 40 HRc minimum.
- Vernier with guide for better thumb position.
- Vernier endurance: 20 000 cycles minimum.
- Vernier screw locking.
- Graduations resistant to chemicals.
- Perfect contrast guaranteeing optimum reading quality.
- Supplied in case with compliance certificate.



 805.M	
A [mm]	200.0
Thickness E [mm]	17.0
Head Height C [mm]	60.0
Accuracy [mm]	0.02
Bias Error ["]	30.0
Weight [g]	423.0