

1150.MT | Micro-Tech® swivel-base vice

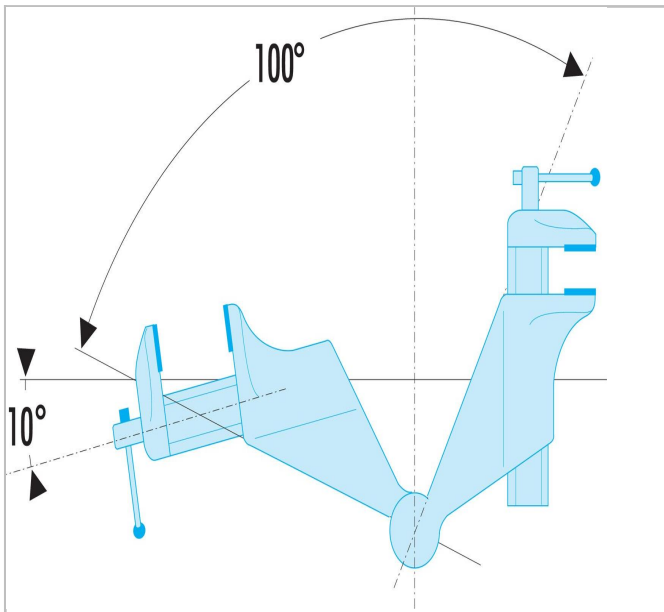

Description:

- Designed for a comfortable work position ensuring high precision.
- Instant locking lever on swivel base.
- Fastener for firm fastening on a support of 80 mm thick max.
- Jaws in glued plastic, width: 50 mm.
- Max opening: 70 mm.
- Max depth: 38 mm.



	1150.MT
Weight [g]	1400.0